

**FB40C 2**  
**FB40 2**  
**FB45C 2**  
**FB45 2**  
**FB50 2**  
**FB40S 2**  
**FB50S 2**

# FB Series

Electric Counterbalance • 4 Wheel Pneumatic Tyres  
80 Volt AC Power • **4.0 – 5.0 tonnes**

## High power performance... low energy use

Reducing your energy bills should not limit your performance. FB Series forklifts are optimised to maximise your operating efficiency – consuming up to 25% less energy. Our **Ecologic (ECO)** models are configured to work naturally and efficiently in any environment, while **Progressive (PRO)** models take your performance to the next level with higher travel and lifting speeds.

A forklift truck can only be as efficient as its operator, so we've incorporated a host of features to maximise your operator's potential. From 'set-it-and-forget-it' performance adjustment systems to spacious, adaptable compartments, we have focused on increasing power, comfort and safety, so your operators can focus on the task in hand.

### Frame and body

- **Robust frame** offers exceptional durability in all working conditions.
- **High-mounted steer axle design** and low centre of gravity ensures high stability.
- **Exceptional visibility** through clear-view overhead guard and mast ensures precise handling with total confidence.

### Drive

- **Choice of control systems (ECO and PRO)** tailors the truck's performance profile to your precise needs.
- **Ecologic (ECO) drive** maximises energy efficiency and peak performance in typical applications.
- **Progressive (PRO) models** deliver higher travel and lift speeds for intensive applications.
- **Cornering control** optimises speed on curves – further increasing stability.



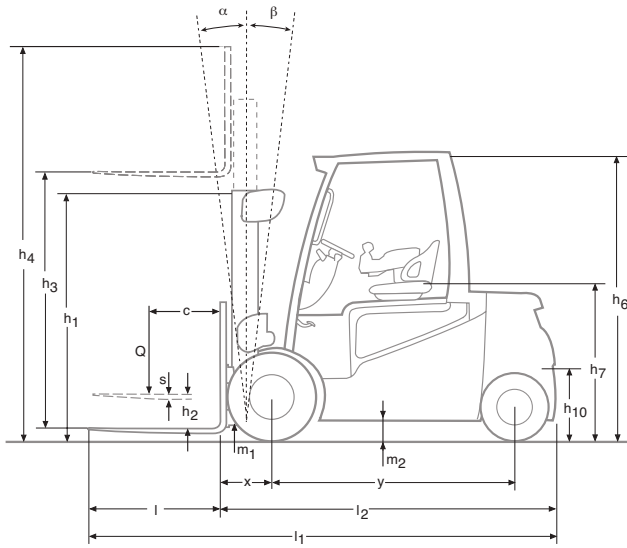

- h1 Height with mast lowered
- h2 Standard free lift
- h3 Lift height
- h4 Height with mast raised
- h5 Full free lift
- Q Lifting capacity, rated load
- c Load centre (distance)

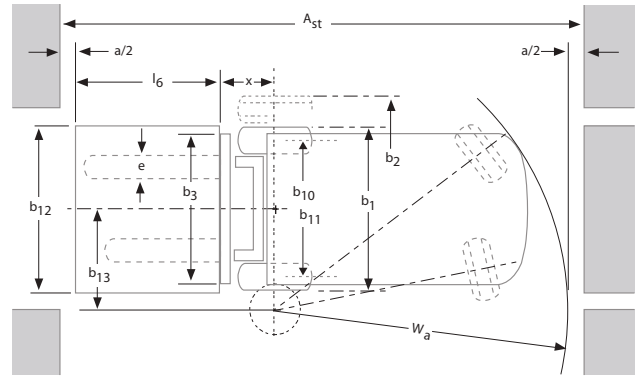

- $A_{st} = W_a + x + l_6 + a$
- $A_{st}$  = Working aisle width
- $W_a$  = Turning radius
- a = Safety clearance =  $2 \times 100$  mm
- $l_6$  = Pallet length (800 or 1000 mm)
- b12 = Pallet width (1200 mm)

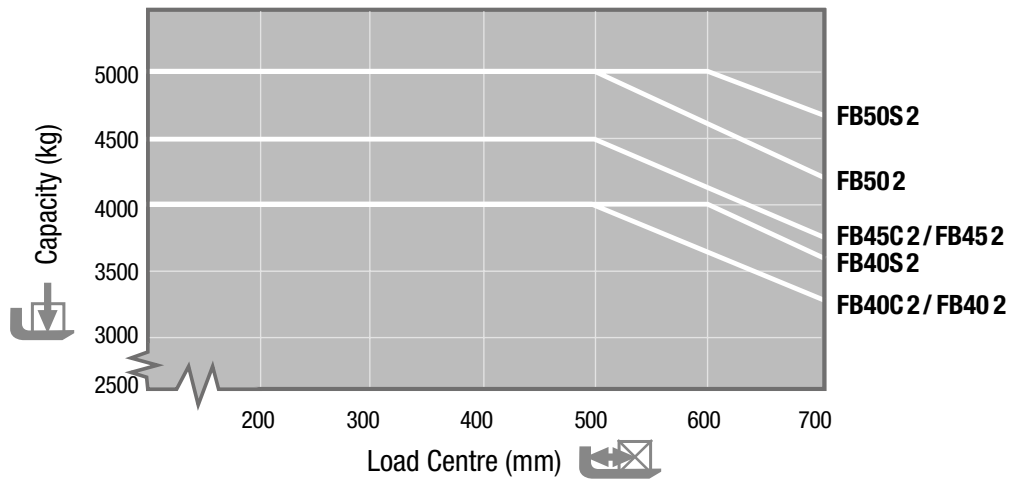

# FB Series

Electric Counterbalance • 4 Wheel Pneumatic Tyres

80 Volt AC Power • **4.0 – 5.0 tonnes**

Characteristics						
1.1	Manufacturer (abbreviation)			Mitsubishi	Mitsubishi	Mitsubishi
1.2	Manufacturer's model designation			FB40C 2	FB40 2	FB45C 2
1.3	Power source: (battery, diesel, LP gas, petrol)			Electric	Electric	Electric
1.4	Operator type: pedestrian, (operator)-standing, -seated			Seated	Seated	Seated
1.5	Load capacity	Q (kg)		4,000	4,000	4,500
1.6	Load centre distance	c (mm)		500	500	500
1.8	Load distance, axle to fork face	x (mm)		510 <sup>1</sup>	510 <sup>1</sup>	510 <sup>1</sup>
1.9	Wheelbase	y (mm)		1856	2000	1856
Weight						
2.1	Truck weight, without load / including battery (simplex mast, lowest lift height)		kg	6726	6701	7186
2.2	Axle loading with maximum load, front/rear (simplex mast, lowest lift height)		kg	9730 / 996	9726 / 975	10608 / 1078
2.3	Axle loading without load, front/rear (simplex mast, lowest lift height)		kg	3553 / 3173	3706 / 2995	3659 / 3527
Wheels, Drive Train						
3.1	Tyres: V=solid, L=pneumatic, SE=solid pneumatic - front/rear			SE / SE	SE / SE	SE / SE
3.2	Tyre dimensions, front			250-15	250-15	28×12.5-15
3.3	Tyre dimensions, rear			21×8-9	21×8-9	21×8-9
3.5	Number of wheels, front/rear (x=driven)			2x/2	2x/2	2x/2
3.6	Track width (centre of tyres), front	b10 (mm)		1115	1115	1155
3.7	Track width (centre of tyres), rear	b11 (mm)		950	950	950
Dimensions						
4.1	Mast tilt, forwards/backwards	a/b	°	6/8	6/8	6/8
4.2	Height with mast lowered (see tables)	h1	(mm)	2300	2300	2286
4.3	Free lift (see tables)	h2	(mm)	150	150	150
4.4	Lift height (see tables)	h3	(mm)	3000	3000	3000
4.5	Overall height with mast raised	h4	(mm)	3676	3676	3660
4.7	Height to top of overhead guard	h6	(mm)	2365	2365	2350
4.8	Seat height	h7	(mm)	1313	1313	1303
4.12	Tow coupling height	h10	(mm)	396	396	396
4.12.1	2nd tow coupling height		(mm)	566	566	566
4.19	Overall length	l1	(mm)	3818	3952	3818
4.20	Length to fork face (includes fork thickness)	l2	(mm)	2668	2812	2668
4.21	Overall width	b1/b2	(mm)	1340	1340	1450
4.22	Fork dimensions (thickness, width, length)	s / e / l	(mm)	50×125×1150	50×125×1150	50×150×1150
4.23	Fork carriage to DIN 15 173 A/B/no			3A	3A	3A
4.24	Fork carriage width	b3	(mm)	1260	1260	1260
4.31	Ground clearance under mast, with load	m1	(mm)	136	136	122
4.32	Ground clearance at centre of wheelbase, with load (forks lowered)	m2	(mm)	150	150	140
4.33	Working aisle width with 1000 × 1200 mm pallets, crosswise	Ast	(mm)	3965	4160	3965
4.34	Working aisle width with 800 × 1200 mm pallets, crosswise	Ast	(mm)	4165	4360	4165
4.35	Turning circle radius	Wa	(mm)	2284	2450	2284
4.36	Minimum distance between centres of rotation	b13	(mm)	660	721	660
Performance						
5.01a	Travel speed, with/without load, eco mode		km/h	14 / 16	14 / 16	14 / 15.5
5.01b	Travel speed, with/without load, pro mode		km/h	15 / 17	15 / 17	15 / 16.5
5.02a	Lifting speed, with/without load, eco mode		m/s	0.31 / 0.43	0.31 / 0.43	0.30 / 0.41
5.02b	Lifting speed, with/without load, pro mode		m/s	0.35 / 0.5	0.35 / 0.5	0.33 / 0.45
5.03a	Lowering speed, with/without load, eco mode		m/s	0.54 / 0.46	0.54 / 0.46	0.52 / 0.47
5.03b	Lowering speed, with/without load, pro mode		m/s	0.55 / 0.5	0.55 / 0.5	0.55 / 0.5
5.05a	Rated drawbar pull, with/without load, eco mode		N	5100 / 5600	5100 / 5600	4900 / 5500
5.05b	Rated drawbar pull, with/without load, pro mode		N	5100 / 5600	5100 / 5600	4900 / 5500
5.06a	Maximum drawbar pull, with/without load (5 min short duty), eco mode		N	14600 / 14900	14600 / 14900	14500 / 14800
5.06b	Maximum drawbar pull, with/without load (5 min short duty), pro mode			14600 / 14900	14600 / 14900	14500 / 14800
5.07a	Gradeability, with/without load, eco mode		N	9.3 / 15.4	9.3 / 15.4	8.1 / 13.5
5.07b	Gradeability, with/without load, pro mode		%	10.8 / 17.7	10.8 / 17.7	9.4 / 15.8
5.08a	Maximum gradeability, with/without load, eco mode		%	14.1 / 22.3	14.1 / 22.3	12.5 / 20.4
5.08b	Maximum gradeability, with/without load, pro mode		%	15.4 / 26.1	15.4 / 26.1	13.7 / 23.9
5.09a	Acceleration time (10 metres) with/without load, eco mode		%	5/2 / 4.4	5.2 / 4.4	5.7 / 4.8
5.09b	Acceleration time (10 metres) with/without load, pro mode		s	5 / 4.4	5 / 4.4	5.5 / 4.8
5.10	Service brakes (mechanical/hydraulic/electric/pneumatic)		s	Electrical	Electrical	Electrical
Electric motors						
6.1	Drive motor capacity (60 min. short duty)			14.5 / 18.0	14.5 / 18.0	14.5 / 18.0
6.2	Lift motor output at 15% duty factor		kW	20 / 24	20 / 24	20 / 24
6.3	Battery to DIN 43 531/35/36 A/B/C/no		kW	A 43536	A 43536	A 43536
6.4	Battery voltage/capacity at 5-hour discharge			80 / 775	80 / 930	80 / 775
6.5	Battery weight		V /Ah	1863	2178	1863
6.6	Energy consumption according to VDI 60 cycle		kg	11	11	12.1
Miscellaneous						
8.1	Type of drive control			Impuls / AC	Impuls / AC	Impuls / AC
8.2	Maximum operating pressure for attachments			200	200	200
8.3	Oil flow for attachments		bar	30	30	30
8.4	Noise level, value at operator's ear (EN 12053)		l/min	<70	<70	<70
8.5	Towing coupling design / DIN type, ref.		dB(A)	15170 / H	15170 / H	15170 / H

	Mitsubishi	Mitsubishi	Mitsubishi	Mitsubishi
	FB45 2	FB50 2	FB40S 2	FB50S 2
	Electric	Electric	Electric	Electric
	Seated	Seated	Seated	Seated
	4500	4990	4000	5000
	500	500	600	600
	510'	510'	510'	510'
	2000	2000	2080	2080
	7161	7549	7176	8036
	10549 / 1112	11282 / 1257	10025 / 1151	11677 / 1359
	3777 / 3385	3772 / 3777	3891 / 3285	3932 / 4104
	SE / SE	SE / SE	SE / SE	SE / SE
	28 × 12.5-15	28 × 12.5-15	28 × 12.5-15	28 × 12.5-15
	21 × 8-9	21 × 8-9	23 × 10-12	23 × 10-12
	2x/2	2x/2	2x/2	2x/2
	1155	1155	1155	1155
	950	950	1200	1200
	6/8	6/8	6/8	6/8
	2286	2286	2286	2287
	150	150	150	150
	3000	3000	3000	3000
	3660	3810	3810	3810
	2350	2350	2350	2350
	1303	1303	1303	1303
	396	396	396	396
	566	566	566	566
	3962	3952	4102	4102
	2812	2812	2952	2952
	1450	1450	1450	1450
	50×150×1150	50×150×1150	50×150×1150	60×150×1150
	3A	3A	3A	4A
	1260	1260	1260	1260
	122	122	122	122
	140	140	150	150
	4160	4160	4379	4379
	4360	4360	4579	4579
	2450	2450	2637	2637
	721	721	673	673
	14 / 15.5	14 / 15	14 / 15.5	13.5 / 14.5
	15 / 16.5	15 / 16	15 / 16.5	14.5 / 15.5
	0.30 / 0.41	0.28 / 0.41	0.30 / 0.41	0.27 / 0.40
	0.33 / 0.45	0.33 / 0.45	0.33 / 0.45	0.31 / 0.45
	0.52 / 0.47	0.52 / 0.47	0.52 / 0.47	0.51 / 0.5
	0.55 / 0.5	0.55 / 0.5	0.55 / 0.5	0.55 / 0.5
	4900 / 5500	4800 / 5400	4900 / 5500	4700 / 5300
	4900 / 5500	4800 / 5400	4900 / 5500	4700 / 5300
	14500 / 14800	14400 / 14700	14500 / 14800	14400 / 14700
	14500 / 14800	14400 / 14700	14500 / 14800	14400 / 14700
	8.1 / 13.5	7.5 / 13.5	8.1 / 13.5	7.1 / 12.7
	9.4 / 15.8	8.8 / 15.8	9.4 / 15.8	8.4 / 15
	12.5 / 20.4	12.1 / 20.0	12.5 / 20.4	11.4 / 18.9
	13.7 / 23.9	13.2 / 23.4	13.7 / 23.4	12.5 / 22.2
	5.7 / 4.8	6.0 / 5.2	5.7 / 4.8	6.4 / 5.5
	5.5 / 4.8	5.8 / 5.2	5.5 / 4.8	6.1 / 5.5
	Electrical	Electrical	Electrical	Electrical
	14.5 / 18.0	14.5 / 18.0	14.5 / 18.0	14.5 / 18.0
	20 / 24	20 / 24	20 / 24	20 / 24
	A 43536	A 43536	A 43536	A 43536
	80 / 930	80 / 930	80 / 930	80 / 930
	2178	2178	2178	2178
	12.1	<12.5	<12.5	13.15
	Impuls / AC	Impuls / AC	Impuls / AC	Impuls / AC
	200	200	200	200
	30	30	30	30
	<70	<70	<70	<70
	15170 / H	15170 / H	15170 / H	15170 / H

### Mast Performance and Capacity

Mast type					Capacity chart (kg)	
FB40S 2 / FB50 2					FB40S 2	FB50 2
	h3 (mm)	h1 (mm)	h2/h5 (mm)	h4 (mm)	Q @ c = 600mm	Q @ c = 500mm
Simplex	2750 <sup>1)</sup>	2165	150	3608	4000	4990
	3000 <sup>1)</sup>	2290	150	3858	4000	4990
	3100 <sup>1)</sup>	2348	150	3958	4000	4990
	3300 <sup>1)</sup>	2440	150	4158	4000	4990
	3500	2548	150	4358	4000	4990
	3700	2640	150	4558	4000	4990
	4000	2795	150	4858	4000	4990
	4300	2940	150	5158	4000	4990
	4500 <sup>1)</sup>	3040	150	5358	4000	4990
	5000	3290	150	5858	4000	4990
	5500	3540	150	6358	4000	4990
	6000	3790	150	6858	3700	4600
	6500	4040	150	7358	–	–
	Duplex	2775 <sup>1)</sup>	2140	1232	3683	4000
3142 <sup>1)</sup>		2323	1415	4050	4000	4990
3342 <sup>1)</sup>		2423	1515	4250	4000	4990
3542		2523	1615	4450	4000	4990
3675		2590	1682	4583	4000	4990
4035		2770	1862	4943	4000	4990
4395 <sup>1)</sup>		2950	2042	5303	4000	4990
5095		3300	2392	6003	4000	4990
5524		3515	2607	6432	–	–
Triplex		4150 <sup>1)</sup>	2140	1232	5058	4000
	4400 <sup>1)</sup>	2223	1315	5308	4000	4990
	4700 <sup>1)</sup>	2323	1415	5608	4000	4990
	4850 <sup>1)</sup>	2373	1465	5758	4000	4990
	5000 <sup>1)</sup>	2423	1515	5908	4000	4990
	5300	2523	1615	6208	4000	4990
	5500	2590	1682	6408	4000	4990
	6000	2770	1862	6908	3750	4440
	6500 <sup>1)</sup>	2950	2042	7408	3500	3890
	7000 <sup>1)</sup>	3120	2212	7908	3280	3340
	7500	3300	2392	8408	–	–

Battery compartment	FB40C/45C	FB40/45/50/40S/50S
Length (min)	1028	1028
Width (min)	855	999
Height (min)	784	784
Minimum weight (80V)	1863	2178



Easy on-off access



Fully adjustable steering column



Clear-view overhead guard



Wide range of optional configurations

Mast type					Capacity chart (kg)	
FB40C 2 / FB40 2 / FB45C 2 / FB45 2					FB40C 2 / FB40 2	FB45C 2 / FB45 2
	h3 (mm)	h1 (mm)	h2/h5 (mm)	h4 (mm)	Q @ c = 500mm	Q @ c = 500mm
Simplex	2750 <sup>1)</sup>	2165	150	3465	4000	4500
	3000 <sup>1)</sup>	2290	150	3715	4000	4500
	3100 <sup>1)</sup>	2348	150	3823	4000	4500
	3300 <sup>1)</sup>	2440	150	4015	4000	4500
	3500	2548	150	4223	4000	4500
	3700	2640	150	4415	4000	4500
	4000	2795	150	4720	4000	4500
	4300	2940	150	5015	4000	4500
	4500 <sup>1)</sup>	3040	150	5215	4000	4500
	5000	3290	150	5715	4000	4500
	5500	3540	150	6215	4000	4500
	6000	3790	150	6715	3700	–
6500	4040	150	7215	–	–	
Duplex	2775 <sup>1)</sup>	2140	1382	3533	4000	4500
	3142 <sup>1)</sup>	2323	1565	3900	4000	4500
	3342 <sup>1)</sup>	2423	1665	4100	4000	4500
	3542	2523	1765	4300	4000	4500
	3675	2590	1832	4433	4000	4500
	4035	2770	2012	4793	4000	4500
	4395 <sup>1)</sup>	2950	2192	5153	4000	4500
	5095	3300	2542	5853	4000	4500
	5524	3515	2757	6282	–	–
	7500	3300	2490	8310	3050	2870

Mast type					Capacity chart (kg)
FB50S 2					
	h3 (mm)	h1 (mm)	h2/h5 (mm)	h4 (mm)	Q @ c = 600mm
Simplex	2480 <sup>1)</sup>	2165	150	3453	5000
	2846 <sup>1)</sup>	2348	150	3819	5000
	3030 <sup>1)</sup>	2440	150	4003	5000
	3246	2548	150	4219	5000
	3430	2640	150	4403	5000
	3740	2795	150	4713	5000
	4030	2940	150	5003	5000
	4230 <sup>1)</sup>	3040	150	5203	5000
	4730	3290	150	5703	5000
	5230	3540	150	6203	5000
	5730	3790	150	6703	–
	6230	4040	150	7203	–
	Duplex	2570 <sup>1)</sup>	2140	1117	3593
2932 <sup>1)</sup>		2323	1300	3955	5000
3132		2423	1400	4155	5000
3332		2523	1500	4355	5000
3465		2590	1567	4488	5000
3825		2770	1747	4848	5000
4185 <sup>1)</sup>		2950	1927	5208	5000
4885		3300	2277	5908	5000
5314		3515	2492	6337	–
Triplex	3875 <sup>1)</sup>	2140	1117	4898	5000
	4120 <sup>1)</sup>	2223	1200	5143	5000
	4420 <sup>1)</sup>	2323	1300	5443	5000
	4720	2423	1400	5743	5000
	5020	2523	1500	6043	5000
	5220	2590	1567	6243	5000
	5750	2770	1747	6773	4760
	6280 <sup>1)</sup>	2950	1927	7303	4450
	6780 <sup>1)</sup>	3120	2097	7803	4250
	7320	3300	2277	8343	–

<sup>1)</sup> Mast not available in combination with 300mm raised operator position, option TP/HI





Clear display



Non-slip low step



Spacious cabin

### Steering system

- **Dynamic steering system** responds effectively to speed and environment for precise, reliable control.

### Brakes

- **Automatic parking brake** delivers added security on ramps and slopes.

### Hydraulics

- **High-efficiency hydraulics** maximise power, while minimising energy loss.

### Electrical and control systems

- **Advanced controller with three-phase AC technology** smoothly adjusts acceleration, speed and braking to suit load, application and driver – reducing energy use, while increasing productive power.
- **Lateral battery changing system** ensures simple, quick and safe changeovers, for round-the-clock performance

### Operator environment and controls

- **Clear display** alerts drivers and service engineers to potential issues – avoiding damage encouraging maintenance.
- **Low step** with non-slip grip and large, level foot-well gives easy on-off access to spacious operator compartment.
- **Operator protection system** prevents all truck movement unless operator is seated with seatbelt secured.
- **Adjustable armrest with integrated fingertip controls** increases operator comfort and precise control.
- **Fully adjustable steering column** can be positioned quickly and easily to suit each driver's exact needs.
- **Fully floating cabin** keeps vibrations to a minimum, reducing operator stress and fatigue – even on the longest shifts.
- **Low-noise technology** means sound level at operator's ear is no louder than a typical conversation.

### Other features

- **RapidAccess** features give quick and easy entry to all areas for checks and maintenance.

### Options include:

- **Progressive (PRO) features pack**
- **Lateral battery changing system**
- **Wide range of accessories**

# when reliability is everything

Like any product bearing the Mitsubishi name, our materials handling equipment benefits from the huge resources and cutting-edge technology of one of the world's largest corporations. So when we promise you **quality, reliability and value for money**, you know it's a guarantee we have the power to deliver.

Every model in our comprehensive, award-winning range of forklift trucks and warehouse equipment is built to a high specification and is designed to keep on working for you... day after day... year after year... whatever the job... whatever the conditions.



To ensure your truck stays in constant productive action, we have a network of local dealers – hand-picked for their commitment to customer care... and backed up by the Mitsubishi Forklift Trucks organisation. No matter where you are, we have a dealer close by – ready and willing to meet your needs.



That friendly local service covers everything from identifying the perfect model and configuration for your application to providing competitive, flexible finance and maintenance packages, unbeatable warranties, long and short term hire, and highly responsive field service and repairs... as well as the industry's quickest and most reliable parts supply.



Only Mitsubishi can give you this combination of global engineering excellence and outstanding local support... only Mitsubishi offers you such a quality product at such an affordable price... and only Mitsubishi places reliability as high as you do in its priorities. Contact your local dealer now and see what Mitsubishi can do for you.



You can find your nearest dealer at [www.mitforklift.com](http://www.mitforklift.com)



CESM1811 (11/16)  
© 2016 MCFE  
Printed in The Netherlands

[mitforklift@mcf.nl](mailto:mitforklift@mcf.nl) [www.mitforklift.com](http://www.mitforklift.com)

NOTE: Performance specifications may vary depending on standard manufacturing tolerances, vehicle condition, types of tyres, floor or surface conditions, applications or operating environment. Trucks may be shown with non-standard options. Specific performance requirements and locally available configurations should be discussed with your distributor of Mitsubishi forklift trucks. Mitsubishi follows a policy of continual product improvement. For this reason, some materials, options and specifications could change without notice.