

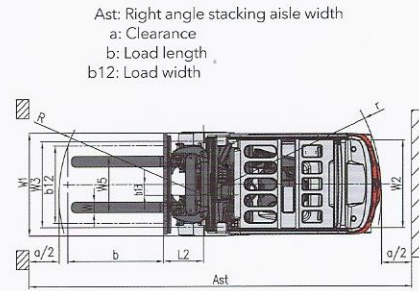

G2 3-3.5t

G2 series dual-drive battery forklift truck

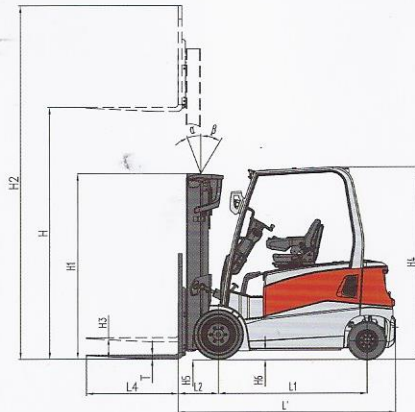

Characteristic				
1.01	Manufacturer			HELI
1.02	Model			CPD30 CPD35
1.03	Configuration number			GD2D GD2D
1.04	Load capacity/rated load	Q	kg	3000 3500
1.05	Service weight incl. battery		kg	5230 5500
1.06	Load centre distance	c	mm	500 500
1.07	Power mode			Battery
1.08	Driving mode			Seated
Wheels & Tyres				
2.01	Tires			SE
2.02	Tyre size, front			23x10-12 23x10-12
2.03	Tyre size, rear			18x7-8 18x7-8
2.04	Wheels, number front rear (x=driven wheels)			2x/2 2x/2
Dimension Parameter				
3.01	Wheelbase	L1	mm	1730 1730
3.02	Load distance, centre of drive axle to fork	L2	mm	463 468
3.03	Mast/fork carriage tilt (fwd/bwd)	α/β	°	6/8 6/8
3.04	Lift height	H	mm	3000 3000
3.05	Lowered mast height	H1	mm	2155 2155
3.06	Free lift	H3	mm	150 150
3.07	Fork dimension	T/W/L4	mm	45x125x1070 50x125x1070
3.08	Length to face of forks	L'	mm	2527 2532
3.09	Overall width	W1	mm	1195 1195
3.10	Overhead guard (cab) height	H4	mm	2240 2240
3.11	Turning radius	r	mm	2075 2075
3.12	Ground clearance, centre of wheelbase	H6	mm	110 110
3.13	Track width, front	W3	mm	975 975
3.14	Track width, rear	W2	mm	990 990
Performance Parameter				
4.01	Travel speed, laden		km/h	19 18
4.02	Travel speed, unladen		km/h	20 19
4.03	Lift speed, laden		m/s	0.46 0.44
4.04	Lift speed, unladen		m/s	0.54 0.54
4.05	Max gradient performance laden		%	21 19
4.06	Max gradient performance unladen		%	29 27
Motor & Controller				
5.01	Drive motor rating (60 min.)	S2	kW	8x2 8x2
5.02	Lift motor rating (15%)	S3	kW	25.5 25.5
5.03	Drive motor control method			MOSFET/AC
5.04	Pump motor control method			MOSFET/AC
Battery				
6.01	Battery acc. To DIN43531 / 35 /36 A, B, C			43536A 43536A
6.02	Battery voltage, nominal capacity Ks	U /K5	V/Ah	80/700 80/700
6.03	Battery dimension l/w/h		mm	1028x855x784 1028x855x784

NOTE:For configuration number,2-ZAPI Controller.



HELI 安徽合力股份有限公司
ANHUI HELI CO., LTD.

ADD:NO.668 Fangxing Street,Economical Development Zone,Hefei ,P.R.China
TEL: (86 551)63639068(America); 63639258(Europe);63639358(Asia); 63662105(Africa & Middle East);63639530(Warehouse Equipment); 63639531(Wheel loader)
FAX:(86 551)63639966
WEBSITE:http://www.helichina.net

MMU 765

AUTHORIZED DEALER