



A / Silver-HELired-Grey

B / HELired-Grey



G2 series 3-4.5 ton stand-on lithium battery tractor is an important equipment in the field of regional logistics. It is mainly used for material transportation in car industry, parts manufacturing and large logistics industry.



G2 series 3-4.5 ton stand-on lithium battery tractor applies HELI family design language to front cover.

HELI

HELI

G2 series 3-4.5 ton stand-on
Lithium battery tractor



ANHUI HELI CO., LTD.
Add / No.668, FangXing Road, Hefei, China
Fax / +86-551-63639966
Tel / +86-551-63639068(America); 63639258(Europe); 63639358(Asia);
63662105(Africa & Middle East); 63639530(Overseas Marketing)



YouTube



Facebook

* Our products are subject to improvements and changes without notice.

Design:Print:Pack:Pin:thru: 2023.03.23

Components are connected by sleek body ridge lines, which brings strong overall modeling and abundant surface changes to the tractor.

Heli Super Lithium System

The superiority of HELI lithium battery tractor is embodied in the used-cost within product lifecycle. Compared with lead-acid battery tractor, HELI lithium battery tractor is more convenient for multiple working shifts. It has lower implicit cost and more economical total running cost.

- Faster charging
- High efficient
- More environmentally friendly
- Long life
- Low temperature resistance

More Safety

- A** Auto-deceleration when turning;
- B** Step-on safety switch avoid misoperation;

Optional card reader or password unlocking device, no optional storage function.

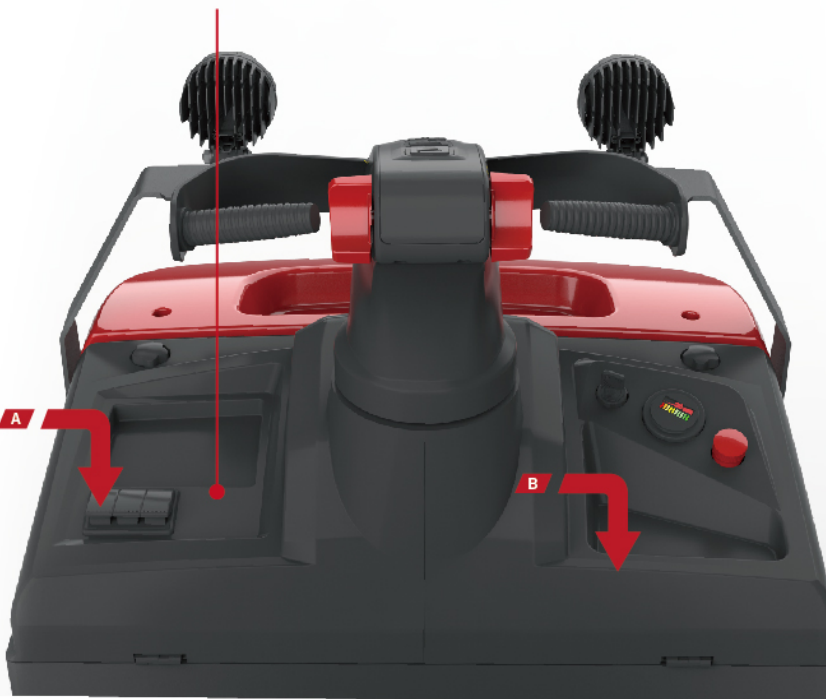

Abundant Storage Space

Convenient for operator; Improve work efficiency



Configuration table			
Standard model	QYD30S-L3G2LI	QYD45S-L3G2LI	
Controller	Imported AC controller		
motor	3kW AC motor		
Steering motor	0.6kW AC motor		
Gearbox	Heli homemade gearbox		
meter	Multi-function LCD instrument		
Control handle	Heli homemade control handle		
Brake	High-strength electromagnetic brake for reliable performance		
Battery capacity	Lithium battery 48V/120Ah		
Tire	Rubber solid tire		
Battery changing method	Pull out the side of the battery		
Optional	Headlights	LED flashing warning light	LED rotating warning light
	Polyurethane solid tire	Lithium battery 48V/202Ah	

Lithium battery advantages



Environment Friendliness

- Zero emission
- Low noise
- Free of heavy metals
- No corrosion
- No acid mist volatilization

Maintenance Free

- Unnecessary of fluid adding and dust proofing
- Daily maintenance free
- Manual maintenance free

Long service life

- Over 75% capacity reserved after 4000 shifts operation
- Longer service life than lead-acid battery in equal working condition
- 5 years or ten thousand hours quality guarantee for high performance Lithium battery assembly

High Efficiency and Energy saving

- 2 hours charging meet 6-8 hours working demand High-energy density, self Discharging rate lower than 1% per month
- 95% energy conversion rate, superior charging and discharging performance
- Flexible to charge, easy to operate, no impact on battery life
- Unnecessary to change battery, cost saving

Suitable for working in both high and low environment

- Lithium battery is better than lead-acid battery when working between -25°C and 55°C

Ergonomic design

Short Handle

Provide flexible and convenient steering.

Adjustable Backrest

0-150mm; Stroke: 0-150mm; Improve driving comfort; Meet driving needs of different heights;

150mm
0mm

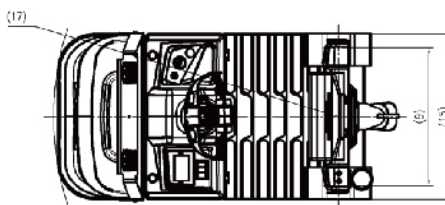
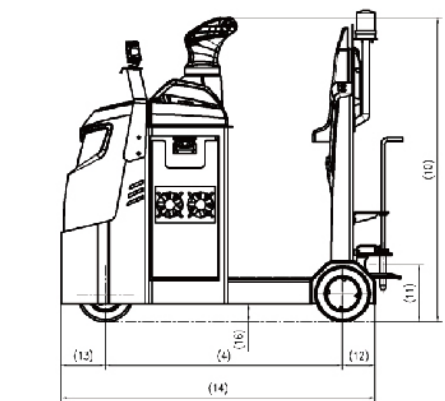

Technical Data

Serial number	Model	Unit	QYD30S-L3G2LI	QYD45S-L3G2LI
1	Driving style		Station type	
2	Rated traction weight	Kg	3000	4500
3	Rated traction	N	2200	
4	Wheelbase	mm	1080	
5	weight	Kg	830	880
6	No-load bridge load before/after	Kg	500/330	550/330
7	Tire (front wheel)		10x4x6.5	
8	Tire (rear wheel)		10x5x6.5	
9	Rear track	mm	630	
10	Full height	mm	1350	
11	Traction hook height	mm	260/360	
12	After hanging	mm	148	
13	Front overhang	mm	201	
14	Full length	mm	1430	
15	Full width	mm	754	
16	Minimum ground clearance	mm	80	
17	Minimum turning radius	mm	1250	
18	Driving speed, full load / no load	Km/h	7/8	6/8
19	Climbing ability, full load / no load	%	5/10	4/10
20	Travel brake		Electric braking and electromagnetic braking	
21	Parking brake		Electromagnetic braking	
22	Drive motor power	kW	3	
23	Steering motor power	kW	0.6	
24	Battery voltage / capacity	V/Ah	Lithium battery 48V/120	
25	Battery weight	Kg	100	